

## AN-X3AUXXX5-X Series

Rev. E

### SMD VCXO

### Ultra-Low Phase Noise with Low G Sensitivity

**Description:** The AN-X3AUXXX5-X Series of SMD Voltage Controlled crystal oscillators (VCXO), provides extremely low phase noise and jitter with Sine-wave or CMOS output in a small surface mount FR4 based package.



## Features

- Small, Low Profile SMD Package
- Ultra-Low Phase Noise
- Low G sensitivity
- No Multiplication – no sub-harmonics
- COTS/Dual use

### Creating a Part Number

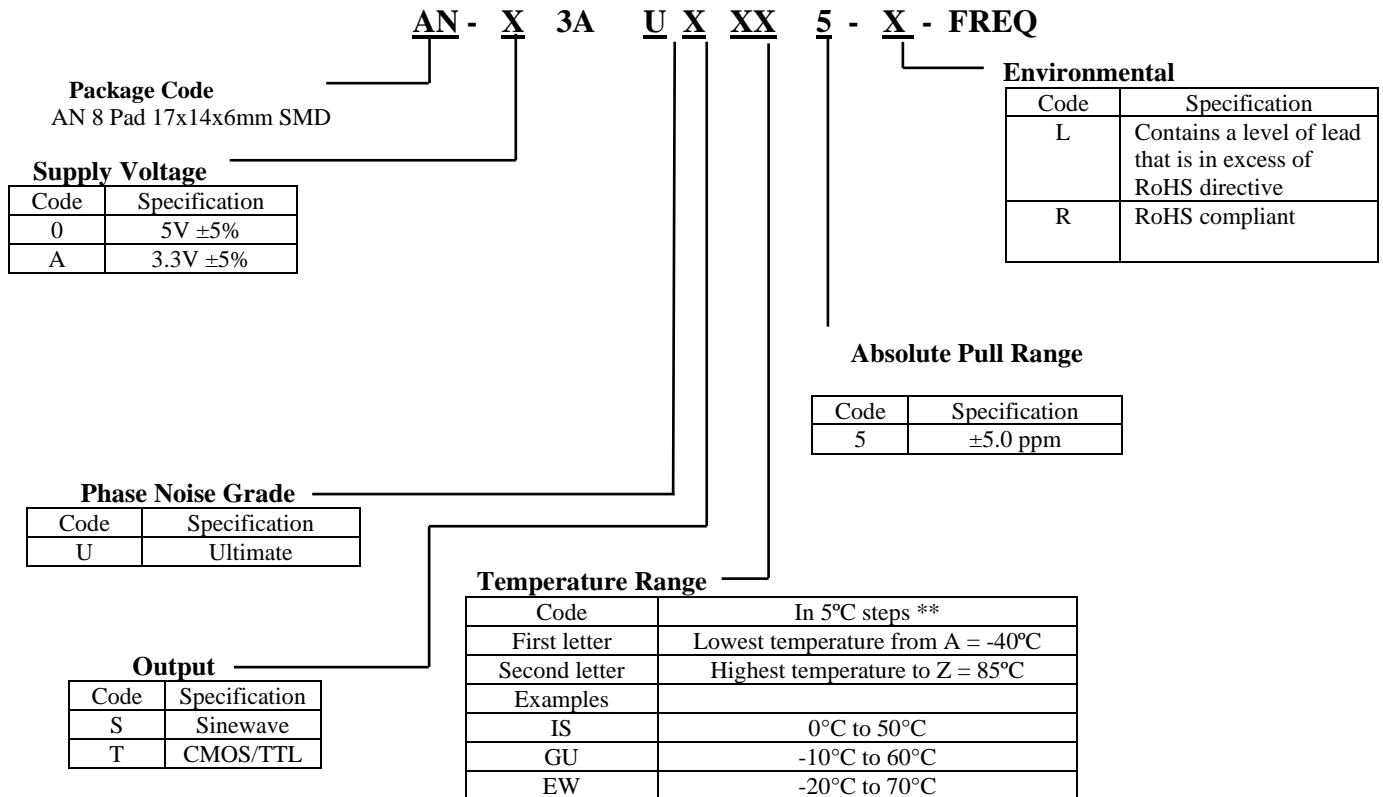

**\*\*Temperature Code Table**

Letter	Temp °C	Letter	Temp °C	Letter	Temp °C	Letter	Temp °C	Letter	Temp °C	Letter	Temp °C
A	-40	F	-15	K	10	P	35	U	60	Z	85
B	-35	G	-10	L	15	Q	40	V	65		
C	-30	H	-5	M	20	R	45	W	70		
D	-25	I	0	N	25	S	50	X	75		
E	-20	J	5	O	30	T	55	Y	80		

\*Note: Not all combinations are available

100 MHz example

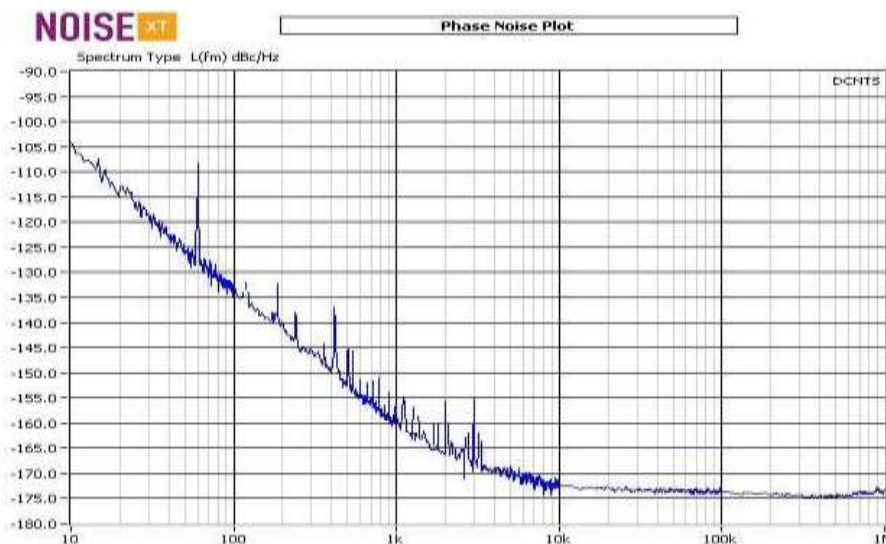

12 MHz example

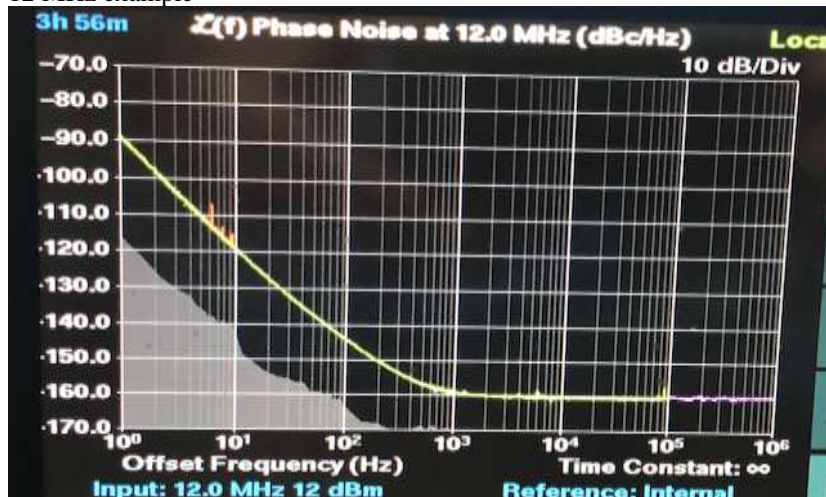

## AN-X3AUXXX5-X Series

Rev. E

Note 1) All parameters, unless otherwise specified, are at nominal conditions, i.e.: T=25°C, Nominal Vcc & Nominal Load

### Specifications

Parameter	Symb	Condition	Min	Typ	Max	Unit	Note
<i>Electrical</i>							
Frequency Range	F	Sine-wave	10		125	MHz	
Input Voltage	Vcc		3.135 4.75	3.30 5.0	3.465 5.25	V	A 0
Input Current	Icc	Sine			40 10	mA	@100MHz, 3.3V @10 MHz, 3.3 V
Frequency Stability	ΔF/F	vs. Temperature vs. Vcc aging		±10 ±0.1 ±1 ±3 ±4		ppm ppm/V ppm/year ppm ppm	See chart  First Year 7 years 10 years
G-sensitivity		Worst Direction		0.2 0.5		ppb/G	100 MHz 10 MHz
Setability	Vset		Vcc/2 - 0.1Vcc	Vcc/2	Vcc/2 + 0.1 Vcc	V	
Load		Sine CMOS	Internally AC-coupled 50 Ohm 10 KOhm // 15 pF				
Output power (output code "S")	P	Sine-wave Into 50 Ohms	7 10	10 13		dBm	3.3V 5.0V
Logic 1 (CMOS)	Voh		0.7Vcc			V	Output Code T
Logic 0 (CMOS)	Vol				0.1V	V	Output Code T
Duty Cycle			45/55		55/45	%	Output Code T
Rise/Fall Time	Tr/Tf			2	3		Output Code T
Spurious		Not setup related			-80	dBc	
Harmonics		Sine-wave		-30	-25	dBc	
SSB Phase Noise	£(Δf)	@ 10 Hz		-95		dBc/Hz	@ 100MHz, Grade U
		@ 100 Hz		-125			
		@ 1 KHz		-152			
		@ 10 KHz		-165			
		@ 100 KHz		-170			
		@ 1 Hz		-90			@ 10 MHz, Grade U
		@ 10 Hz		-120			
		@ 100 Hz		-143			
		@ 1 KHz		-158			
		@ 10 KHz		-160			
		@ 100 KHz		-160			
ADEV		0.1 s to 1 s		1E-11			@ 10 MHz, Grade U
Input Impedance			>10K Ohm				
Control voltage	Vc		0		Vcc	V	
Modulation bandwidth	MB				1	KHz	
Initial Pullability	ΔF/F	As shipped		±20		ppb	
Absolute Pull Range (Guaranteed Capture Range)	ΔF/F	Over All Conditions	±5	±7		ppm	Includes temperature, Vcc variations, and aging 10 years
<i>Absolute Maximum Ratings</i>							
Input Break Down Voltage	Vcc		-0.5		5.5	V	
Storage temper.	Ts		-55		105	°C	
Control Voltage	Vc		-1		4	V	

## AN-X3AUXXX5-X Series

Rev. E

### Environmental and Mechanical

<b>Operating temp. range</b>	-20°C to 70°C MAX, for wider range only 5V Vcc option is available, contact factory, see table to specify.
<b>Mechanical Shock</b>	Per MIL-STD-202, Method 213, Cond. E
<b>Thermal Shock</b>	Per MIL-STD-883, Method 1011, Cond. A
<b>Vibration</b>	Per MIL-STD-883, Method 2007, Cond. A
<b>Soldering Conditions</b>	See MAX reflow profile; The device may be reflowed once. Reflowing upside down is not allowed. NO CLEAN assembly is recommended.
<b>Hermetic Seal</b>	Leak rate less than $1 \times 10^{-8}$ atm.cc/s of helium (crystal only)

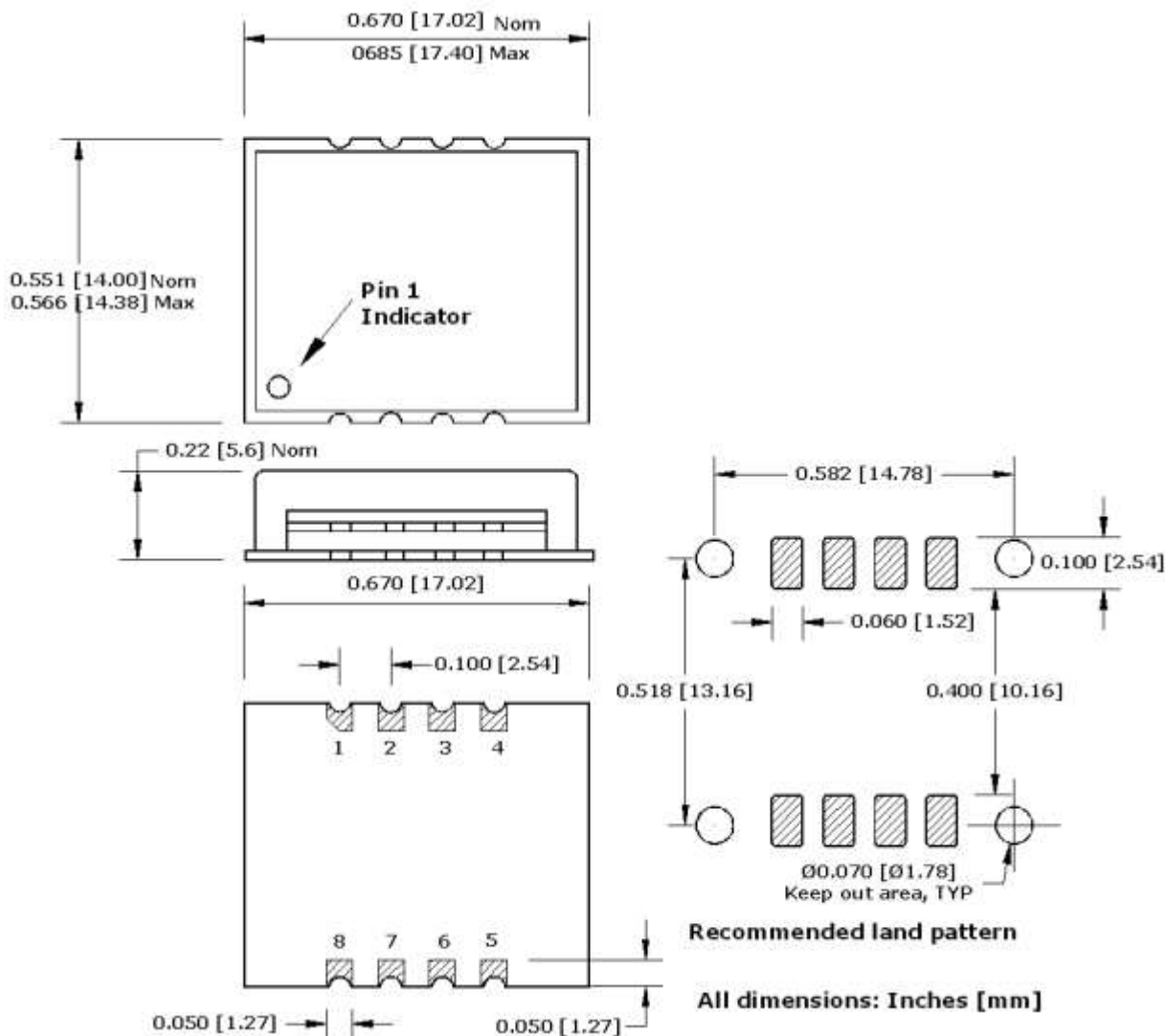

### Electrical Connections

Pin out	Pin 1=Vcc; Pin 2, Pin 3, Pin 4, Pin 8 = GND; Pin 5=Output; Pin 6= Voltage Control; Pin 7 Do Not Connect
---------	---

Rev. E

**Maximum solder reflow profile**

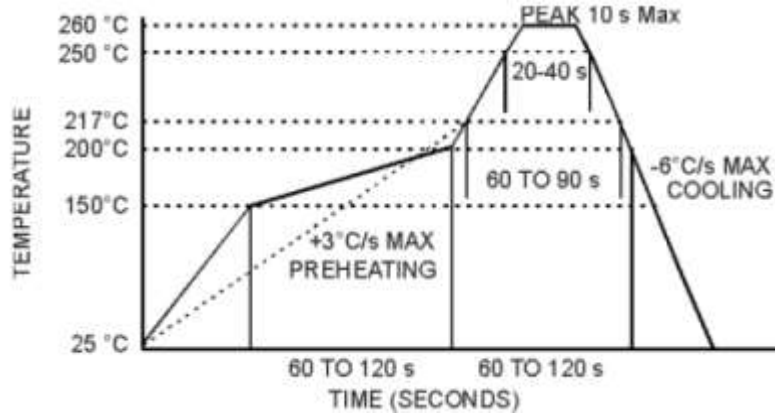

The device may be reflowed once. Reflowing upside down is not allowed. NO CLEAN assembly is recommended.